

Formular cerere burghie

Cantitate (buc) _____ pcs. numar de gauri necesare _____

Material

materialul de taiat _____ rezistenta la tractiune/ duritate _____ N/mm² HRC

Piesa de prelucrat

adancime de gaurire _____ mm toleranta gaurii _____

Material

carbura solida
 HSS-E
 HSS-CO
 HSS

Agent racire

interior exterior
 Presiune _____ bar

Similar cu reperul:

N/mm²
HRC

HA cilindrica bar

HB Weldon

HE Wistle notch

Coada cilindrica

B con Morse

dimensiune

Dimensiuni

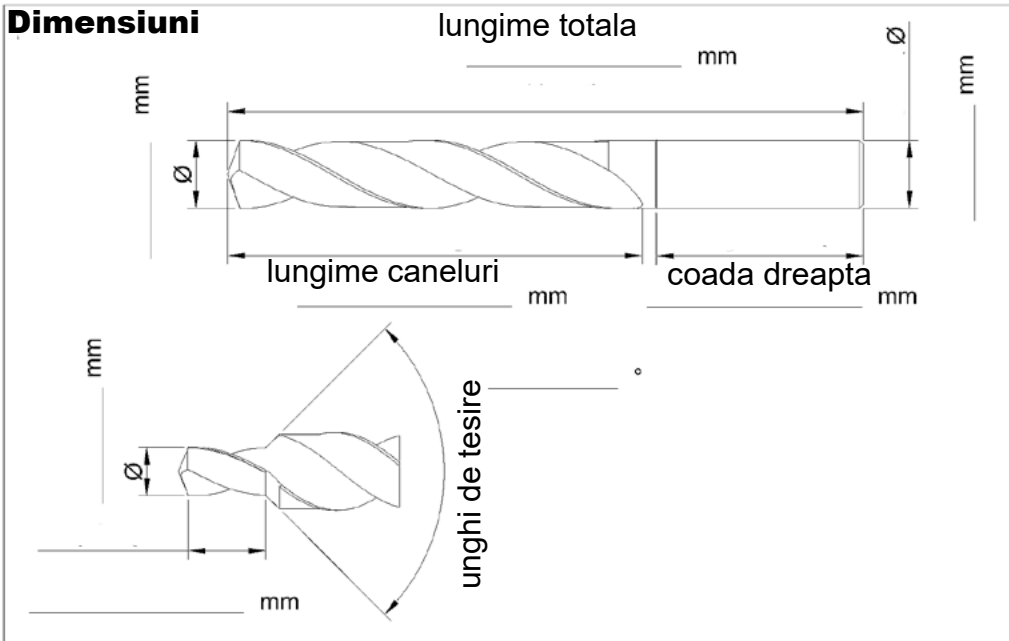

Acoperire

polisat AlTiN nano TiN TiAlSiN TiAlN

Companie:
 Pers. de contact:
 Telefon:
 E-mail:

Data: