

THE NEW VALUE FRONTIER



Threading insert with
molded chipbreaker

TQ chipbreaker

TQ chipbreaker



Increased productivity with improved chip control

Stable chip control

Low cutting force and suppressed vibration

Improved tool life with new insert grades



Threading insert with molded chipbreaker

TQ chipbreaker

Increase productivity with improved chip control
Improved tool life with new insert grades

1 Stable chip control

Stable chip control with asymmetric chipbreaker design

Chipbreaker geometry

Stable chip control regardless of cutting direction

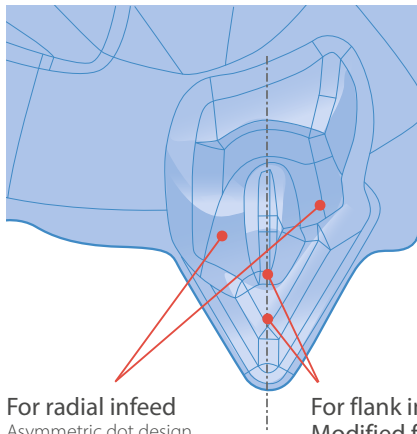

For radial infeed
Asymmetric dot design controls chip-flow direction

For flank infeed / Modified flank infeed
Breaks chips easily with shallow breaker depth

Chip control performance (Internal evaluation)

Radial infeed

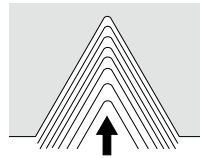

TQ chipbreaker



Competitor A

Modified flank infeed

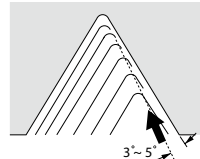

TQ chipbreaker



Competitor A

Cutting conditions: $V_c = 150$ m/min, $a_p = 0.12$ mm (4th pass), $L = 25$ mm, wet, 16ER150 ISO type
M45 × P1.5 workpiece: 15CrMo4

2 Low cutting force and suppressed vibration

Strong edge and low cutting force

Comparison of cutting force Radial infeed (Internal evaluation)

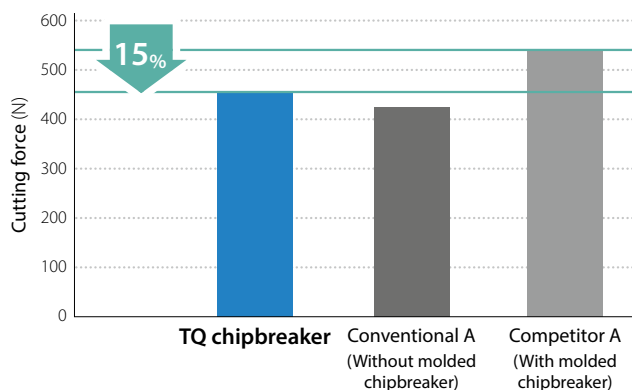

Cutting conditions: $V_c = 150$ m/min, wet, 16ER150 ISO type
Cutting force shows the average of 6 passes, M35 × P1.5 workpiece: 15CrMo4

Cutting force comparison Modified flank infeed (Internal evaluation)

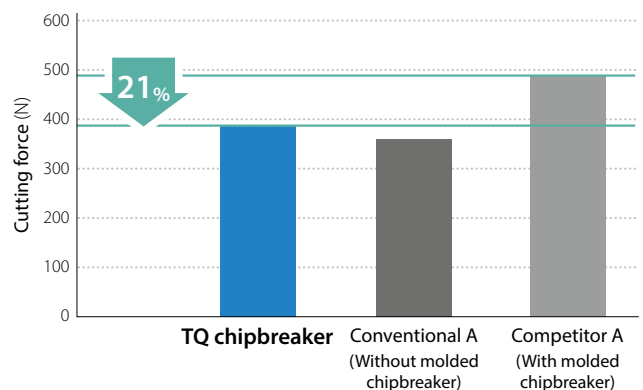

Cutting conditions: $V_c = 150$ m/min, adjusted angle: 5 degrees, wet, 16ER150 ISO type
Cutting force shows the average of 6 passes, M35 × P1.5 workpiece: 15CrMo4

3 Improved tool life with new insert grades

For steel machining **PR1215**
 For stainless steel machining **PR1515 (First recommendation)** **PR1535 (Stability focused)**

Wear resistance comparison (Internal evaluation)

Workpiece: 34CrMo4

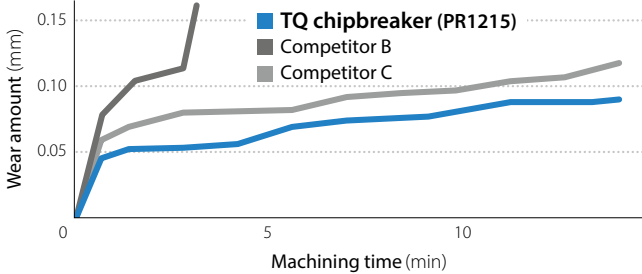

Cutting conditions: Vc = 150 m/min, P = 1.5 mm, number of passes = 6, wet, 16ER150 ISO type Radial infeed

Workpiece: X5CrNi1810

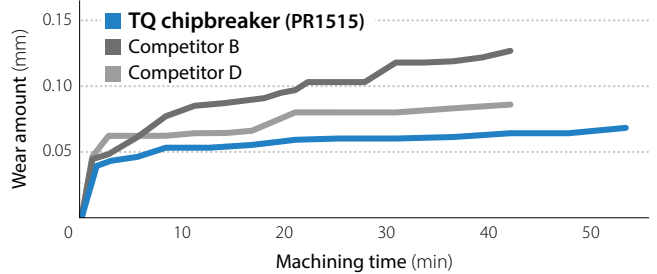

Cutting conditions: Vc = 100 m/min, P = 1.5 mm, number of passes = 8, wet, 16ER150 ISO type Radial infeed

Case studies

Handle steel tube

n = 1,000 min⁻¹ (Vc = 130 m/min)
 Number of passes: 7
 P = 1.5 mm
 Wet (Water soluble)
 16ER150 ISO-TQ
 PR1215

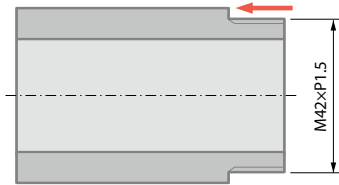

Tool life

TQ chipbreaker PR1215

300 pcs/edge

x1.5

Competitor B

200 pcs/edge or less

TQ chipbreaker (PR1215) achieves 1.5 times the tool life of Competitor B with good chip control

(User evaluation)

Nut C45

n = 1,000 min⁻¹ (Vc = 95 m/min)
 Number of passes: 7
 P = 1.5 mm
 Wet (Water soluble)
 16ER150 ISO-TQ
 PR1215

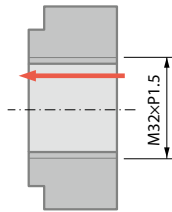

Tool life

TQ chipbreaker PR1215

500 pcs/edge

x1.6

Conventional B

300 pcs/edge or less

TQ chipbreaker (PR1215) achieves 1.6 times the tool life of competitor B without breakage

(User evaluation)

Piping parts X5CrNi1810

n = 1,500 min⁻¹ (Vc = 65 m/min)
 P = 1.0 mm
 Wet (Oil)
 16ER100 ISO-TQ
 PR1535

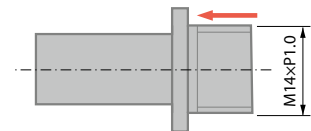

Tool life (Fixed quantity 1.200 pcs/edge)

TQ chipbreaker PR1535



Competitor E



Wear: Large amount

Against competitor E, TQ chipbreaker (PR1535) provided stable machining and a better edge condition in fixed a quantity without sudden cracking

(User evaluation)

External threading inserts

Metric (M) 60° full profile

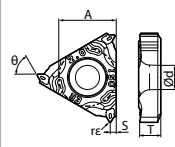
Insert		Description	Applicable thread	Pitch		Dimensions (mm)					θ	MEGACOAT		MEGACOAT NANO			
				mm	TPI	A	T	ød	rε	S		PR1215		PR1515		PR1535	
												R	L	R	L	R	L
Full profile		16ER 100ISO-TQ	M	1.00					0.12	0.80	60°	●		●		●	
		125ISO-TQ		1.25					0.15	0.90		●		●		●	
		150ISO-TQ		1.50					0.19	1.00		●		●		●	
		175ISO-TQ		1.75	—	9.525	3.68	4.0	0.22	1.60		●		●		●	
		200ISO-TQ		2.00					0.25	1.50		●		●		●	
		250ISO-TQ		2.50					0.33	1.60		●		●		●	
		300ISO-TQ		3.00					0.41	1.60		●		●		●	

PR1215/PR1515/PR1535 (threading inserts) are sold in 5 piece box

●: Available

Unified (UN) 60° full profile

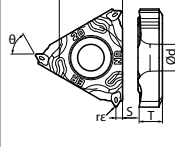
Insert		Description	Applicable thread	Pitch		Dimensions (mm)					θ	MEGACOAT		MEGACOAT NANO			
				mm	TPI	A	T	ød	rε	S		PR1215		PR1515		PR1535	
												R	L	R	L	R	L
Full profile		16ER 24UN-TQ	UN, UNF		24				0.12	0.80	60°	●		●		●	
		20UN-TQ			20				0.15	1.00		●		●		●	
		18UN-TQ			18				0.18	1.00		●		●		●	
		16UN-TQ			16				0.20	1.10		●		●		●	
		14UN-TQ		—	14	9.525	3.68	4.0	0.23	1.50		●		●		●	
		13UN-TQ			13				0.25	1.50		●		●		●	
		12UN-TQ			12				0.27	1.50		●		●		●	
		10UN-TQ			10				0.34	1.50		●		●		●	
		08UN-TQ			8				0.43	1.75		●		●		●	

PR1215/PR1515/PR1535 (threading inserts) are sold in 5 piece box

●: Available

Parallel pipe [G (PF), whitworth (W) 55° full profile

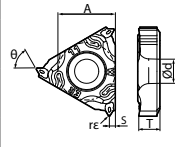
Insert		Description	Applicable thread	Pitch		Dimensions (mm)					θ	MEGACOAT		MEGACOAT NANO				
				TPI		A	T	ød	rε	S		PR1215		PR1515		PR1535		
				G (PF)	W							R	L	R	L	R	L	
Full profile		16ER 19W-TQ	G (PF) W		—				0.16	1.0	55°	●		●		●		
		16W-TQ			—	16				0.19		1.1	●		●		●	
		14W-TQ			14	14	9.525	3.68	4.0	0.23		1.5	●		●		●	
		11W-TQ			11	11				0.30		1.5	●		●		●	

PR1215/PR1515/PR1535 (threading inserts) are sold in 5 piece box

●: Available

Tapered pipe [R(PT), (BSPT)] 55° full profile

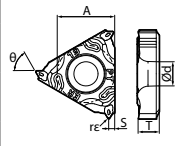
Insert		Description	Applicable thread	Pitch		Dimensions (mm)					θ	MEGACOAT		MEGACOAT NANO			
				mm	TPI	A	T	ød	rε	S		PR1215		PR1515		PR1535	
												R	L	R	L	R	L
Full profile		16ER 28BSPT-TQ	R (PT) (BSPT)		28				0.10	0.8	55°	●		●		●	
		19BSPT-TQ			19				0.16	1.0		●		●		●	
		14BSPT-TQ		—	14	9.525	3.68	4.0	0.22	1.6		●		●		●	
		11BSPT-TQ			11				0.29	1.6		●		●		●	

PR1215/PR1515/PR1535 (threading inserts) are sold in 5 piece box

●: Available

External threading inserts

Metric (M), unified (UN) 60° partial profile

Insert		Description	Applicable thread	Pitch		Dimensions (mm)					θ	MEGACOAT		MEGACOAT NANO			
				mm	TPI	A	T	ød	rε	S		PR1215		PR1515		PR1535	
												R	L	R	L	R	L
Partial profile		16ER A60-TQ G60-TQ AG60-TQ	M UN UNF	0.5-1.5	48-16	9.525	3.68	4.0	0.06	1.00	60°	●	●	●	●	●	
				1.75-3	14-8							●	●	●	●		
				0.5-3	48-8							●	●	●	●		

PR1215/PR1515/PR1535 (threading inserts) are sold in 5 piece box

● : Available

Parallel Pipe [G (PF)], tapered pipe [R(PT), (BSPT)], whitworth (W) 55° partial profile

Insert		Description	Applicable thread	Pitch		Dimensions (mm)					θ	MEGACOAT		MEGACOAT NANO			
				TPI		A	T	ød	rε	S		PR1215		PR1515		PR1535	
				G (PF) R (PT)	W							R	L	R	L	R	L
Partial profile		16ER A55-TQ G55-TQ AG55-TQ	G (PF) R (PT) W	28, 19	40-16	9.525	3.68	4.0	0.06	1.00	55°	●	●	●	●	●	
				14, 11	14-8							●	●	●	●		
				28-11	40-8							●	●	●	●		

PR1215/PR1515/PR1535 (threading inserts) are sold in 5 piece box

● : Available

Internal threading inserts

Metric (M) 60° full profile

Insert Right-handed insert shown		Description	Applicable thread	Pitch		Dimensions (mm)					θ		MEGACOAT		MEGACOAT NANO	
				mm	TPI	A	T	ød	rε	S			PR1215	PR1515	PR1535	
				R	L	R	L	R	L	R	L					
Full profile		11IR 100ISO-TQ	M	1.00	—	6.35	3.18	3.0	0.07	0.8	60°	●	●	●	●	
		125ISO-TQ		1.25					0.08	1.1		●	●	●	●	
		150ISO-TQ		1.50					0.11	1.1		●	●	●	●	
		175ISO-TQ		1.75					0.12	1.1		●	●	●	●	
		16IR 100ISO-TQ	M	1.00	—	9.525	3.68	4.0	0.07	0.8	60°	●	●	●	●	
		125ISO-TQ		1.25					0.08	1.1		●	●	●	●	
		150ISO-TQ		1.50					0.11	1.1		●	●	●	●	
		175ISO-TQ		1.75					0.12	1.1		●	●	●	●	
		200ISO-TQ	2.00	0.14	1.5	●	●	●	●							
		250ISO-TQ	2.50	0.17	1.5	●	●	●	●							
		300ISO-TQ	3.00	0.19	1.6	●	●	●	●							

PR1215/PR1515/PR1535 (threading inserts) are sold in 5 piece box

●: Available

Unified (UN) 60° full profile

Insert		Description	Applicable thread	Pitch		Dimensions (mm)					θ		MEGACOAT		MEGACOAT NANO	
				mm	TPI	A	T	ød	rε	S			PR1215	PR1515	PR1535	
				R	L	R	L	R	L	R	L					
Full profile		16IR 24UN-TQ	UN,UNF	—	24	9.525	3.68	4.0	0.06	0.8	60°	●	●	●	●	
		20UN-TQ			20				0.08	1.0		●	●	●	●	
		18UN-TQ			18				0.09	1.0		●	●	●	●	
		16UN-TQ			16				0.10	1.1		●	●	●	●	
		14UN-TQ			14				0.12	1.5		●	●	●	●	
		13UN-TQ			13				0.13	1.5		●	●	●	●	
		12UN-TQ			12				0.14	1.5		●	●	●	●	
		10UN-TQ			10				0.17	1.5		●	●	●	●	
		08UN-TQ			8				0.21	1.8		●	●	●	●	

PR1215/PR1515/PR1535 (threading inserts) are sold in 5 piece box

●: Available

Parallel pipe [G (PF)], whitworth (W) 55° full profile

Insert		Description	Applicable thread	Pitch		Dimensions (mm)					θ		MEGACOAT		MEGACOAT NANO	
				TPI		A	T	ød	rε	S			PR1215	PR1515	PR1535	
				G (PF)	W						R	L	R	L	R	L
Full profile		16IR 19W-TQ	G (PF) W	—	19	9.525	3.68	4.0	0.16	1.0	55°	●	●	●	●	
		16W-TQ			16				0.19	1.1		●	●	●	●	
		14W-TQ			14				0.23	1.5		●	●	●	●	
		11W-TQ			11				0.30	1.5		●	●	●	●	

PR1215/PR1515/PR1535 (threading inserts) are sold in 5 piece box

●: Available

Tapered Pipe [Rc(PT), (BSPT)] 55° Full Profile

Insert		Description	Applicable thread	Pitch		Dimensions (mm)					θ		MEGACOAT		MEGACOAT NANO	
				mm	TPI	A	T	ød	rε	S			PR1215	PR1515	PR1535	
				R	L						R	L	R	L		
Full profile		11IR 28BSPT-TQ	Rc (PT) (BSPT)	—	28	6.35	3.18	3.0	0.10	0.6	55°	●	●	●	●	
		19BSPT-TQ			19				0.16	0.78		●	●	●	●	
		14BSPT-TQ			14				0.22	0.97		●	●	●	●	
		16IR 14BSPT-TQ			14	9.525	3.68	4.0	0.22	0.97		●	●	●	●	
		11BSPT-TQ			11				0.29	1.5		●	●	●	●	

PR1215/PR1515/PR1535 (threading inserts) are sold in 5 piece box

●: Available

Recommended cutting conditions ★: 1st recommendation ☆: 2nd recommendation

Workpiece material	Recommended insert grade (Vc m/min)		
	MEGACOAT	MEGACOAT NANO	
	PR1215	PR1515	PR1535
Carbon steel	★ 100 – 150	—	—
Initial D.O.C. (Radial)	0.3 mm or less	—	—
Alloy steel	★ 100 – 150	—	—
Initial D.O.C. (Radial)	0.3 mm or less	—	—
Stainless steel	—	★ 60 – 100	☆ 40 – 80
Initial D.O.C. (Radial)	—	0.25 mm or less	0.25 mm or less

Coolant is recommended. For stainless steel threading, please set a smaller initial D.O.C. and take two or three more passes than threading for carbon steel. (See page 7-8)

Infeed methods

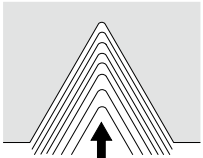
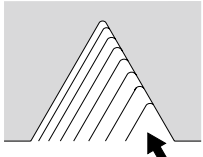
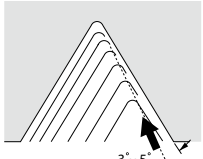
Infeed methods	Features
 <p>Radial infeed</p>	<ul style="list-style-type: none"> • General method • The cutting edge moves towards the center of the workpiece with each pass • Suitable for small pitch size threading • V-shape chips are generated and chip control may be difficult depending on the workpiece material
 <p>Flank infeed</p>	<ul style="list-style-type: none"> • Used for large pitch size threading • No D.O.C. on right side of the figure causes insert wear • Chips flow to one side
 <p>Modified flank infeed</p>	<ul style="list-style-type: none"> • Adjusted variation of flank infeed above • No D.O.C. is reduced • Chips flow to one side

Depth of cut and number of passes

11 / 16 (Full profile)

(D.O.C. shows the value of radial D.O.C.)

Thread type	Pitch mm & TPI	Description	C (mm)	Total D.O.C. (mm)	No. of passes	1	2	3	4	5	6	7	8	9	10	11	12	13	14	15	16			
						1	2	3	4	5	6	7	8	9	10	11	12	13	14	15	16			
Metric	External thread	16ER 100ISO-TQ	0.64	0.72	5	0.23	0.19	0.15	0.10	0.05														
		125ISO-TQ	0.80	0.88	6	0.26	0.21	0.16	0.12	0.08	0.05													
		150ISO-TQ	0.95	1.03	6	0.26	0.24	0.21	0.16	0.11	0.05													
		175ISO-TQ	1.11	1.19	8	0.26	0.22	0.19	0.16	0.13	0.10	0.08	0.05											
		200ISO-TQ	1.27	1.35	10	0.26	0.21	0.18	0.16	0.14	0.12	0.10	0.08	0.05										
		250ISO-TQ	1.57	1.65	12	0.26	0.23	0.21	0.18	0.14	0.12	0.12	0.10	0.10	0.05	0.05								
	300ISO-TQ	1.87	1.95	14	0.26	0.24	0.22	0.20	0.18	0.16	0.16	0.14	0.12	0.10	0.10	0.08	0.06	0.05	0.05	0.02				
	Internal thread	111R 100ISO-TQ	0.60	0.68	5	0.20	0.18	0.15	0.11	0.04														
		125ISO-TQ	0.74	0.82	7	0.20	0.18	0.14	0.12	0.08	0.06	0.04												
		150ISO-TQ	0.88	0.96	8	0.24	0.18	0.14	0.10	0.08	0.07	0.05												
		175ISO-TQ	1.02	1.10	9	0.24	0.18	0.16	0.14	0.10	0.10	0.08	0.05											
		1.00 mm	161R 100ISO-TQ	0.60	0.68	5	0.20	0.18	0.15	0.11	0.04													
1.25 mm		125ISO-TQ	0.74	0.82	7	0.20	0.18	0.14	0.12	0.08	0.06	0.04												
1.50 mm	150ISO-TQ	0.88	0.96	8	0.22	0.18	0.14	0.12	0.10	0.08	0.07	0.05												
1.75 mm	175ISO-TQ	1.02	1.10	9	0.22	0.18	0.16	0.14	0.12	0.10	0.08	0.05	0.05											
2.00 mm	200ISO-TQ	1.18	1.26	10	0.24	0.20	0.18	0.14	0.12	0.10	0.10	0.08	0.05	0.05	0.05									
2.50 mm	250ISO-TQ	1.46	1.54	12	0.26	0.22	0.18	0.16	0.14	0.12	0.10	0.10	0.08	0.08	0.08	0.05	0.05							
3.00 mm	300ISO-TQ	1.76	1.84	14	0.26	0.24	0.21	0.18	0.16	0.16	0.15	0.13	0.12	0.10	0.10	0.07	0.05	0.05	0.05	0.02				
Unified	External thread	16ER 24UN-TQ	0.67	0.75	5	0.24	0.20	0.16	0.10	0.05														
		20UN-TQ	0.80	0.88	6	0.24	0.20	0.16	0.13	0.10	0.05													
		18TPI	0.89	0.97	6	0.26	0.22	0.18	0.15	0.11	0.05													
		16TPI	1.01	1.09	7	0.26	0.22	0.18	0.15	0.12	0.11	0.05												
		14TPI	1.15	1.23	8	0.26	0.22	0.18	0.16	0.14	0.12	0.10	0.05											
		13TPI	1.24	1.32	9	0.26	0.22	0.18	0.16	0.14	0.12	0.11	0.08	0.05										
		12TPI	1.34	1.42	11	0.26	0.22	0.18	0.16	0.13	0.12	0.10	0.08	0.07	0.05	0.05								
		10TPI	1.59	1.67	12	0.26	0.22	0.20	0.18	0.16	0.14	0.12	0.10	0.10	0.07	0.05	0.05	0.05						
		8TPI	1.98	2.06	14	0.26	0.24	0.22	0.20	0.18	0.16	0.16	0.14	0.14	0.12	0.12	0.10	0.08	0.05	0.05				
		Internal thread	161R 24UN-TQ	0.62	0.70	5	0.22	0.19	0.15	0.10	0.04													
			20UN-TQ	0.75	0.83	6	0.22	0.20	0.16	0.12	0.08	0.05												
			18TPI	0.83	0.91	6	0.24	0.20	0.18	0.14	0.10	0.05												
	16TPI		0.94	1.02	7	0.24	0.20	0.18	0.14	0.11	0.10	0.05												
	14TPI		1.07	1.15	8	0.24	0.22	0.18	0.14	0.12	0.10	0.10	0.05											
	13TPI		1.15	1.23	9	0.24	0.22	0.18	0.14	0.12	0.10	0.10	0.08	0.05										
	12TPI		1.24	1.32	11	0.24	0.22	0.16	0.15	0.12	0.10	0.10	0.07	0.07	0.05	0.04								
	10TPI		1.48	1.56	12	0.24	0.22	0.20	0.16	0.15	0.12	0.12	0.10	0.09	0.07	0.05	0.04	0.04						
	8TPI		1.86	1.94	14	0.24	0.22	0.20	0.18	0.16	0.16	0.16	0.14	0.14	0.12	0.12	0.10	0.07	0.05	0.04				
	Parallel pipe		External thread	16ER 19W-TQ	0.89	0.97	6	0.27	0.22	0.18	0.15	0.10	0.05											
				14TPI	1.19	1.27	9	0.27	0.22	0.18	0.16	0.11	0.10	0.10	0.08	0.05								
				11TPI	1.50	1.58	12	0.27	0.22	0.18	0.16	0.12	0.12	0.12	0.10	0.10	0.07	0.07	0.05					
		Internal thread	161R 19W-TQ	0.88	0.96	6	0.25	0.21	0.20	0.15	0.10	0.05												
			14TPI	1.19	1.27	9	0.27	0.22	0.18	0.16	0.11	0.10	0.10	0.08	0.05									
			11TPI	1.50	1.58	12	0.27	0.22	0.18	0.16	0.12	0.12	0.12	0.10	0.10	0.07	0.07	0.05						
Whitworth	External thread	16TPI	1.05	1.13	8	0.25	0.21	0.18	0.16	0.12	0.08	0.08	0.05											
		14TPI	1.19	1.27	9	0.27	0.22	0.18	0.16	0.11	0.10	0.10	0.08	0.05										
		11TPI	1.50	1.58	12	0.27	0.22	0.18	0.16	0.12	0.12	0.12	0.10	0.10	0.07	0.07	0.05							
	Internal thread	161R 16W-TQ	1.05	1.13	8	0.25	0.21	0.18	0.16	0.12	0.08	0.08	0.05											
		14TPI	1.19	1.27	9	0.27	0.22	0.18	0.16	0.11	0.10	0.10	0.08	0.05										
		11TPI	1.50	1.58	12	0.27	0.22	0.18	0.16	0.12	0.12	0.12	0.10	0.10	0.07	0.07	0.05							
Tapered pipe	External thread	16ER 28BSPT-TQ	0.58	0.63	5	0.20	0.15	0.13	0.11	0.04														
		19TPI	0.86	0.94	6	0.26	0.20	0.18	0.15	0.10	0.05													
		14TPI	1.16	1.24	9	0.22	0.20	0.18	0.16	0.14	0.12	0.10	0.08	0.04										
	Internal thread	111R 28BSPT-TQ	0.58	0.63	5	0.20	0.16	0.13	0.10	0.04														
		19TPI	0.86	0.94	7	0.22	0.20	0.18	0.14	0.10	0.06	0.04												
		14TPI	1.16	1.24	9	0.22	0.20	0.18	0.16	0.14	0.12	0.10	0.08	0.04										
14TPI	1.16	1.24	9	0.22	0.20	0.18	0.16	0.14	0.12	0.10	0.08	0.04												
11TPI	1.48	1.56	12	0.26	0.22	0.18	0.16	0.12	0.12	0.12	0.11	0.10	0.10	0.07	0.07	0.05								

Caution for full profile insert

- When using full profile insert, pre machining with finishing allowance by thread diameter 0.05-0.08mm
- Final D.O.C. for finishing should be 0.02 - 0.05 mm
- Prepare chamfering for C0.3 - C0.5 to prevent cracking the insert in the 1st pass
- Coolant is recommended

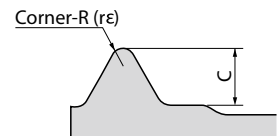

(D.O.C. shows the value of radial D.O.C.)

Corner-R (r ε) selection for partial profiling inserts

	External thread	Internal thread
Metric unified	$r\epsilon \leq 0.1443P$	$r\epsilon \leq 0.0720P$
Parallel pipe (Whitworth)	For both external and Internal thread	
Tapered pipe	$r\epsilon \leq 0.1373P$	

Metric, unified thread

Corner-R (r ε) of internal threading is almost half of that of external

Parallel pipe, tapered pipe, whitworth thread

Same corner-R (r ε) for both external and internal threading

$r\epsilon$: Corner-R P: Pitch (Metric) $(= \frac{25.4}{n})$ n: TPI

Depth of cut and number of passes

60°/55° (Partial profile)

(D.O.C. shows the value of radial D.O.C.)

Thread type	Pitch mm & TPI	Description	Corner-R (rε)	Total D.O.C. (mm)	No. of passes	1	2	3	4	5	6	7	8	9	10	11	12	13	14	15	16			
Metric	External thread	0.5 mm	16ER A60-TQ	0.06	0.33	5	0.10	0.08	0.07	0.05	0.03													
			AG60-TQ	0.06	0.33	5	0.10	0.08	0.07	0.05	0.03													
		0.75 mm	16ER A60-TQ	0.06	0.51	6	0.14	0.11	0.09	0.07	0.06	0.04												
			AG60-TQ	0.06	0.51	6	0.14	0.11	0.09	0.07	0.06	0.04												
		1.00 mm	16ER A60-TQ	0.06	0.70	7	0.18	0.13	0.12	0.09	0.08	0.06	0.04											
			AG60-TQ	0.06	0.70	7	0.18	0.13	0.12	0.09	0.08	0.06	0.04											
		1.25 mm	16ER A60-TQ	0.06	0.89	8	0.18	0.15	0.14	0.12	0.10	0.08	0.07	0.05										
			AG60-TQ	0.06	0.89	8	0.18	0.15	0.14	0.12	0.10	0.08	0.07	0.05										
		1.50 mm	16ER A60-TQ	0.06	1.08	9	0.21	0.17	0.16	0.14	0.11	0.09	0.08	0.07	0.05									
			AG60-TQ	0.06	1.08	9	0.21	0.17	0.16	0.14	0.11	0.09	0.08	0.07	0.05									
1.75 mm	16ER G60-TQ	0.22	1.11	8	0.24	0.20	0.18	0.16	0.13	0.10	0.09	0.06	0.04											
	AG60-TQ	0.06	1.27	11	0.22	0.20	0.18	0.13	0.11	0.09	0.09	0.08	0.07	0.06	0.04									
2.00 mm	16ER A60-TQ	0.22	1.30	10	0.24	0.20	0.18	0.16	0.14	0.12	0.10	0.09	0.07	0.06	0.04									
	AG60-TQ	0.06	1.46	11	0.25	0.22	0.20	0.16	0.14	0.12	0.10	0.09	0.09	0.08	0.06	0.04								
2.50 mm	16ER G60-TQ	0.22	1.67	12	0.25	0.22	0.20	0.18	0.19	0.14	0.12	0.10	0.08	0.06	0.04									
	AG60-TQ	0.06	1.84	13	0.25	0.22	0.20	0.18	0.17	0.14	0.12	0.11	0.10	0.09	0.08	0.06	0.04	0.04	0.04	0.05				
3.00 mm	16ER G60-TQ	0.22	2.05	14	0.25	0.23	0.22	0.20	0.18	0.16	0.14	0.13	0.12	0.11	0.10	0.09	0.07	0.05						
	AG60-TQ	0.06	2.22	15	0.27	0.25	0.22	0.20	0.18	0.16	0.14	0.13	0.12	0.11	0.10	0.09	0.07	0.05	0.05					
Unified	External thread	48 TPI	16ER A60-TQ	0.06	0.35	5	0.10	0.08	0.07	0.06	0.04													
			AG60-TQ	0.06	0.35	5	0.10	0.08	0.07	0.06	0.04													
		24 TPI	16ER A60-TQ	0.06	0.75	7	0.18	0.15	0.13	0.10	0.08	0.07	0.04											
			AG60-TQ	0.06	0.75	7	0.18	0.15	0.13	0.10	0.08	0.07	0.04											
		20 TPI	16ER A60-TQ	0.06	0.91	8	0.18	0.16	0.14	0.12	0.10	0.09	0.07	0.05										
			AG60-TQ	0.06	0.91	8	0.18	0.16	0.14	0.12	0.10	0.09	0.07	0.05										
		18 TPI	16ER A60-TQ	0.06	1.01	8	0.20	0.18	0.16	0.14	0.12	0.08	0.08	0.05										
			AG60-TQ	0.06	1.01	8	0.20	0.18	0.16	0.14	0.12	0.08	0.08	0.05										
		16 TPI	16ER A60-TQ	0.06	1.15	10	0.22	0.18	0.15	0.13	0.11	0.10	0.08	0.08	0.06	0.04								
			AG60-TQ	0.06	1.15	10	0.22	0.18	0.15	0.13	0.11	0.10	0.08	0.08	0.06	0.04								
		14 TPI	16ER G60-TQ	0.22	1.15	9	0.20	0.18	0.16	0.14	0.13	0.12	0.10	0.07	0.05									
			AG60-TQ	0.06	1.32	11	0.22	0.20	0.18	0.15	0.13	0.10	0.09	0.08	0.07	0.06	0.04							
13 TPI	16ER G60-TQ	0.22	1.26	9	0.24	0.20	0.18	0.16	0.14	0.12	0.10	0.07	0.05											
	AG60-TQ	0.06	1.43	11	0.25	0.23	0.20	0.16	0.14	0.12	0.10	0.08	0.06	0.05	0.04									
12 TPI	16ER G60-TQ	0.22	1.38	10	0.25	0.22	0.20	0.17	0.15	0.12	0.10	0.07	0.06	0.04										
	AG60-TQ	0.06	1.55	12	0.24	0.20	0.18	0.16	0.15	0.14	0.12	0.10	0.09	0.07	0.06	0.04	0.04							
10 TPI	16ER G60-TQ	0.22	1.71	12	0.25	0.22	0.20	0.18	0.16	0.15	0.14	0.12	0.10	0.08	0.06	0.05	0.06	0.04						
	AG60-TQ	0.06	1.87	13	0.25	0.22	0.20	0.18	0.20	0.16	0.14	0.12	0.11	0.10	0.08	0.08	0.05	0.06	0.04					
9 TPI	16ER G60-TQ	0.22	1.92	13	0.27	0.24	0.22	0.20	0.18	0.16	0.14	0.12	0.11	0.10	0.08	0.06	0.06	0.04	0.07					
	AG60-TQ	0.06	2.08	14	0.27	0.24	0.22	0.20	0.18	0.16	0.14	0.13	0.12	0.11	0.10	0.08	0.09	0.07	0.05					
8 TPI	16ER G60-TQ	0.22	2.19	15	0.27	0.25	0.22	0.20	0.18	0.16	0.14	0.12	0.12	0.11	0.10	0.10	0.09	0.08	0.05	0.05				
	AG60-TQ	0.06	2.35	16	0.30	0.25	0.23	0.20	0.18	0.17	0.16	0.14	0.12	0.12	0.11	0.10	0.09	0.08	0.05	0.05	0.05			
Parallel pipe Tapered pipe	External thread	28 TPI	16ER A55-TQ	0.06	0.67	7	0.16	0.14	0.10	0.09	0.08	0.06	0.04											
			AG55-TQ	0.06	0.67	7	0.16	0.14	0.10	0.09	0.08	0.06	0.04											
		19 TPI	16ER A55-TQ	0.06	1.02	8	0.20	0.18	0.16	0.14	0.12	0.10	0.07	0.05										
			AG55-TQ	0.06	1.02	8	0.20	0.18	0.16	0.14	0.12	0.10	0.07	0.05										
		14 TPI	16ER G55-TQ	0.22	1.20	9	0.22	0.19	0.17	0.15	0.13	0.12	0.10	0.08	0.04	0.06	0.05	0.04						
AG55-TQ	0.06		1.40	11	0.24	0.22	0.19	0.16	0.14	0.12	0.10	0.08	0.06	0.05	0.04									
11 TPI	16ER G55-TQ	0.22	1.60	12	0.24	0.22	0.20	0.18	0.16	0.14	0.13	0.10	0.08	0.06	0.05	0.04	0.05	0.03						
	AG55-TQ	0.06	1.79	13	0.25	0.22	0.21	0.20	0.18	0.16	0.14	0.12	0.10	0.08	0.06	0.05	0.04	0.03						
Whitworth	External thread	48 TPI	16ER A55-TQ	0.06	0.37	5	0.12	0.09	0.07	0.05	0.04													
			AG55-TQ	0.06	0.37	5	0.12	0.09	0.07	0.05	0.04													
		24 TPI	16ER A55-TQ	0.06	0.79	7	0.18	0.16	0.14	0.11	0.08	0.07	0.05											
			AG55-TQ	0.06	0.79	7	0.18	0.16	0.14	0.11	0.08	0.07	0.05											
		20 TPI	16ER A55-TQ	0.06	0.96	8	0.20	0.18	0.15	0.13	0.10	0.08	0.07	0.05										
			AG55-TQ	0.06	0.96	8	0.20	0.18	0.15	0.13	0.10	0.08	0.07	0.05										
		18 TPI	16ER A55-TQ	0.06	1.07	9	0.20	0.17	0.16	0.14	0.11	0.09	0.08	0.07	0.05									
			AG55-TQ	0.06	1.07	9	0.20	0.17	0.16	0.14	0.11	0.09	0.08	0.07	0.05									
		16 TPI	16ER A55-TQ	0.06	1.22	11	0.20	0.18	0.16	0.13	0.11	0.10	0.09	0.08	0.07	0.06	0.04							
			AG55-TQ	0.06	1.22	11	0.20	0.18	0.16	0.13	0.11	0.10	0.09	0.08	0.07	0.06	0.04							
		14 TPI	16ER G55-TQ	0.22	1.20	9	0.22	0.19	0.17	0.15	0.13	0.12	0.10	0.08	0.04	0.05	0.04							
			AG55-TQ	0.06	1.40	11	0.24	0.22	0.19	0.16	0.14	0.12	0.10	0.08	0.06	0.05	0.04							
12 TPI	16ER G55-TQ	0.22	1.44	10	0.24	0.22	0.20	0.18	0.15	0.12	0.10	0.09	0.07	0.05	0.04									
	AG55-TQ	0.06	1.64	12	0.24	0.22	0.20	0.18	0.16	0.14	0.12	0.												

Thread methods (TQ chipbreaker)

External thread (L-hand thread / R-hand thread)

External thread			
Left-hand thread	Toolholder	(R) R-hand	
	Insert	(R) R-hand	
	The direction of spindle revolution	M04	
	Toolholder	(R) R-hand	
Insert	(R) R-hand		
The direction of spindle revolution	M03		
Right-hand thread	Toolholder	(R) R-hand	
	Insert	(R) R-hand	
	The direction of spindle revolution	M03	
	Toolholder	(R) R-hand	
Insert	(R) R-hand		
The direction of spindle revolution	M04		

* These tables are based on KTN/KTNS toolholder

Internal thread (L-hand thread / R-hand thread)

Internal threading			
Left-hand thread	Toolholder	(R) R-hand	
	Insert	(R) R-hand	
	The direction of spindle revolution	M03	
Right-hand thread	Toolholder	(R) R-hand	
	Insert	(R) R-hand	
	The direction of spindle revolution	M03	

* These tables are based on SIN/CIN toolholder

KTN/ KTNS external threading toolholder

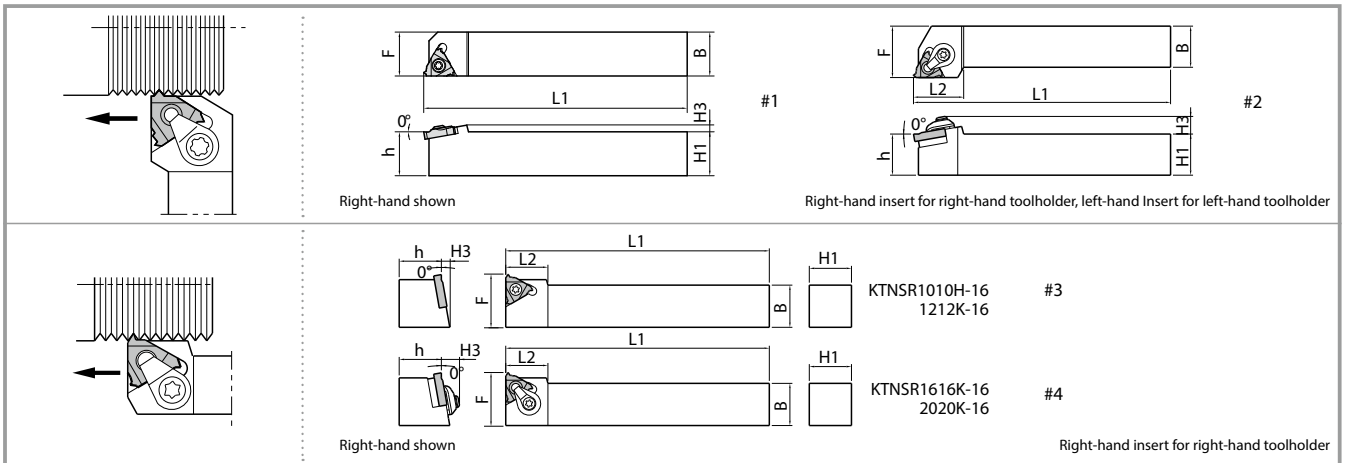

Toolholder dimensions

Description	Availability		Dimensions (mm)							Drawing	Spare parts					Applicable inserts
	R	L	H1=h	H3	B	L1	L2	F	Clamp set		Clamp screw	Wrench	Shim	Shim screw		
KTNR/L	1216JX-16F	●	●	12	3	16	120	—	16	#1	—	SB-3.5TR	LTW-15S	—	—	16ER/L
	1616H-16	●	●	16	8.5		100	25	20	#2	CPS-5S	—	FT-15	TN-32	SP3X8	
	1616JX-16F	●	●		3		120	—	16	#1	—	SB-3.5TR	LTW-15S	—	—	
	2020H-16	●	●	20	8.5	100	25	25	#2	CPS-5S	—	FT-15	TN-32	SP3X8		
	2020JX-16F	●	●		3	120	—	20	#1	—	SB-3.5TR	LTW-15S	—	—		
	2020K-16	●	●		8.5	125	—	25	#2	CPS-5S	—	FT-15	TN-32	SP3X8		
	2525M-16	●	●	25	8.5	25	150	25	30	#2	CPS-5S	—	FT-15	TN-32	SP3X8	
KTNSR	1010H-16	●		10	8.5	10	100	16	16	#3	—	SB-3.5TR	FT-15	—	—	16ER...
	1212K-16	●		12		12	18	18	#3	—	SB-3.5TR	—		—		
	1616K-16	●		16		16	125	18	22	#4	CPS-5S	—	FT-15	TN-32	SP3X8	
	2020K-16	●		20		20	—	20	27.4	#4	CPS-5S	—	FT-15	TN-32	SP3X8	

KTNR2020H-16 indicates short-shank type

●: Available

S...KTNL external threading sleeve holder

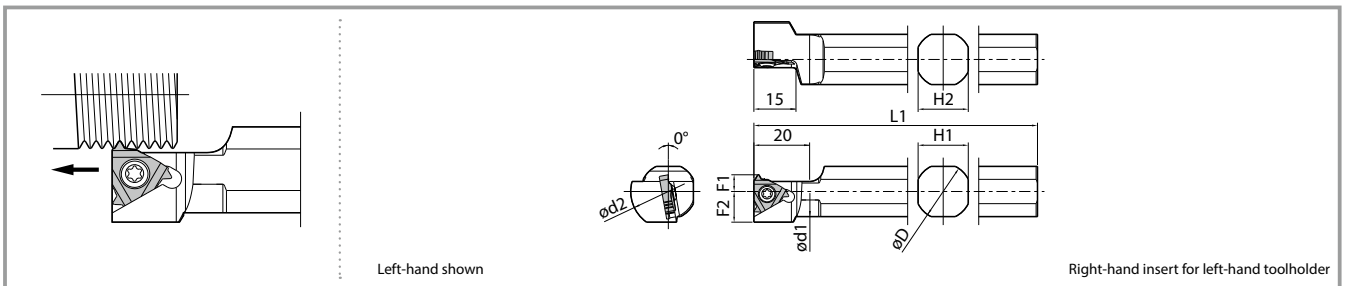

Toolholder Dimensions

Description	Availability	Dimensions (mm)							Spare parts		Applicable inserts
		øD	L1	F1	F2	ød1	ød2	H1=H2	Clamp screw	Wrench	
S16F-KTNL16	●	16	85	6	11	15	27	15	SB-3.5TR	LTW-15S	16ER...
S19K-KTNL16	●	19.05	120			18		17			
S20K-KTNL16	●	20				19		18			
S22K-KTNL16	●	22				21		20			
S25.0H-KTNL16	●	25	100			10	14	24			
S25K-KTNL16	●	25.4	120								

●: Available

SIN/CIN internal threading holder

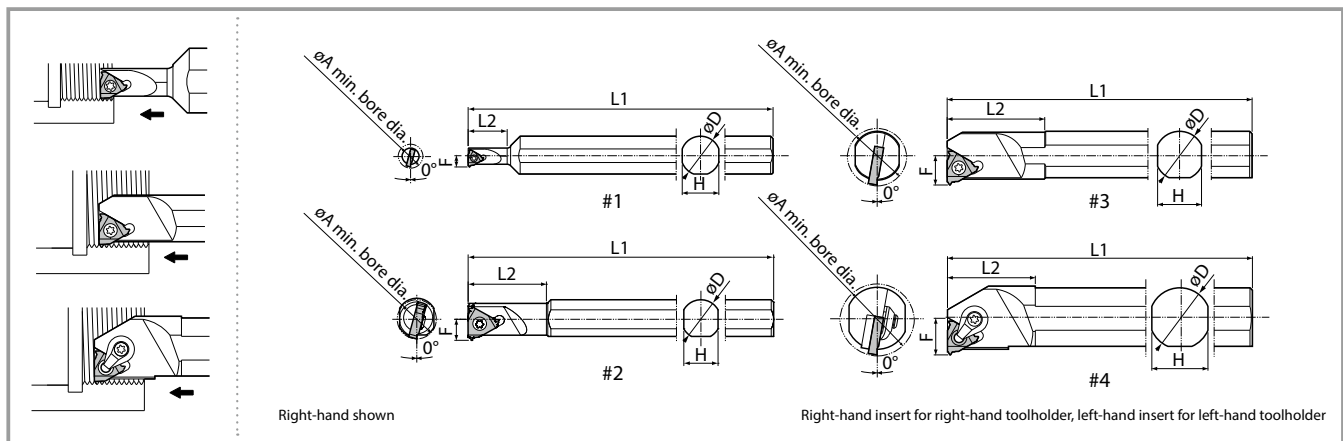

Toolholder dimensions

Description	Availability		Min. bore dia. øA	Dimensions (mm)					Drawing	Spare parts					Applicable inserts			
	R	L		øD	H	L1	L2	F		Clamp Screw	Clamp Set	Wrench	Shim	Shim Screw				
SIN R/L 1216S-11E	●	●	12	16	14	150	25	6.3	#1	SB-2TR	—	FT-8	—	—	11I R/L			
1516S-11	●	●	15				30	7.5										
1616S-16	●	●	16				#2	14	150	32	8.6	#3	SB-3.5TR	—	FT-15	—	—	16I R/L
2016S-16	●	●	20							37	10.0							
2420S-16	●	●	24							20	18	180	40	12.0				
CIN R/L 3025S-16	●	●	30	25	23	200	36	15.0	#4	—	CPS-55	FT-15	TN-32	SP3X8	16I R/L			
3732S-16	●	●	37	32	30	250	45	18.5										

●: Available

Guide for internal threading

For internal threading, pay extra attention to "stabilizing diameters of pre-drilled holes" and "chip evacuation"

1. Stabilizing diameters of pre-drilled holes

Because small pitch internal threads have a small corner radius, any variation in the diameter of pre-drilled holes will greatly affect the tool life of the insert. Please minimize any variation of pre-drilled holes and add an air pass to the first thread pass for safety. Pre-drilled holes are finished to stabilize the first thread pass.

2. Chip evacuation

If the threading cycle continues with chips tangled on the holder or the part, it may damage the insert. Use the methods below to make sure chips do not become entangled.

1. When running the first part of a setup

Run the program in single block. Start each thread pass 50mm-100mm from the workpiece face to allow room for the coolant to remove chips from the tool on each pass.

2. When running the second part of a setup

Run through the full threading cycle and again check that chips are removed from the tool before going into production.

