





Prismenaufnahmen nach DIN 69881

Dove tail tool holder according to DIN 69881
Porte-outils prismatiques conforme DIN 69881

DIN 69 881 VDI 3425 / 3

Werkzeughalter mit Prisma
Toolholder with Dove Tail Clamp
Porte-outil prismatique

			Form	Page
Radial-Werkzeughalter Axial-Werkzeughalter	Radial-Tool holder Axial-Toolholder	Porte-outil radial Porte-outil axial	A1 / A2 B1 / B2	2.1
Mehrfach Werkzeughalter	Multi-Tool holder	Porte-outil multiple	C1 - C3	2.2 / 2.3 /2.6
Bohrstangenhalter	Boring bar holder	Porte-barre d'alésage	D1 - D3	2.3 / 2.4
Kühlmittelverteiler	Coolant Distributer	Conduit d'arrosage		2.5
Stellhülsen	Automotive Shank holders	Porte-outil réglable		2.5 - 2.5
Doppel-Bohrstangenhalter Werkzeughalterplatten	Twin boring bor holder Tool holder adaptor Plates	Porte-barre pour outil à plaquettes carbure		2.7
Bohrhalter für Wendeplattenbohrer	Boring Bar for Carbide tipped Tools	Porte-barre pour outil à plaquettes		2.8 / 2.9
Werkzeughalter für kleine Borstangen höhenverstellbar	Toolholders, Height adjustable for small Boring Bars	Porte-barre réglable en hauteur pour petit diamètre		2.10
Aufnahmehülsen	Sleeves	Douilles		2.11 / 2.12
Kegelaufnahmen	Morse Taper Shank holder	Porte-outil pour queue à cône Morse		2.13
Spannzangengutter	Collet Chucks	Porte-pinces		
Stellhülsen	Morse Taper Shank holder	Porte-outil pour embout réglable		2.14
MK Reduzierhülsen	Collet Chuck	Douille de réduction		

Vierkant-Queraufnahme

Turning Toolholder

Radial-Porte outil

DIN 69881 Teil 2 VDI 3425 Bl. 3
Form A

DIN 69881 Part 2 VDI 3425 Sheet 3
Form A

DIN 69881 Partie 2 VDI 3425 page 3
Forme A

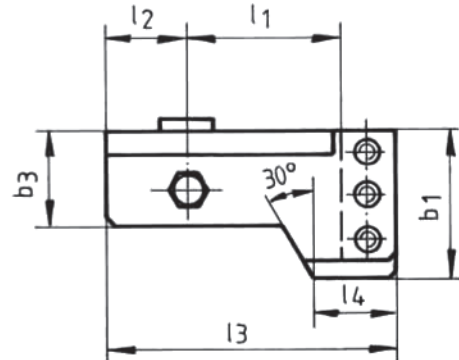
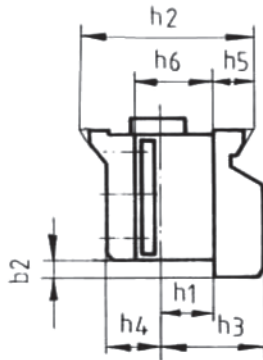
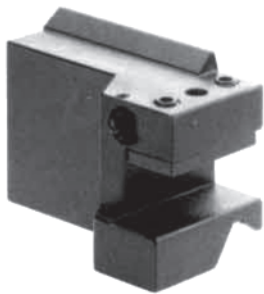

Form A2 Rechte Ausführung (wie gezeichnet)
A1 Ausführung links (spiegelbildlich)

Form A2 Right side (as drawn)
A1 Left side (mirror image)

Forme A2 Exécution droite dessin ci-dessus
A1 Exécution gauche dessin inverse

Nenngröße h ₁ Size Taille	Nr. Rechts Right Droite	Nr. Links Left Gauche	Maße/Dimensions											
			h ₂	b ₁	b ₂	b ₃	h ₃	h ₄	h ₅ ± 0,05	h ₆ max.	l ₁ +0,5 0	l ₂	l ₃	l ₄
16	10.100	10.101	56	50	6	32	40	19	12	22	49	31	94	34
20	10.110	10.111	72	63	6	40	43	27	16	29	49	39	110	45
25	10.120	10.121	90	72	9	40	50	35,5	20	34	73	39	138	45
32	10.130	10.131	115	85	9	50	60	40	25,5	41	112	49	191	50
40	10.140	10.141	140	110	12	60	78	57,5	30	53	115	59	209	55

2

Vierkant-Längsaufnahme

Turning Toolholder for Square Tool

Axial-Porte outil

DIN 69881 Teil 3 VDI 3425 Bl. 3

DIN 69881 Part 3 VDI 3425 Sheet 3

DIN 69881 Partie 3 VDI 3425 page 3

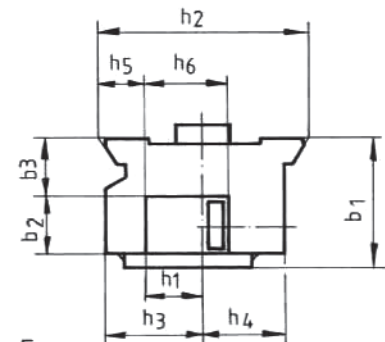
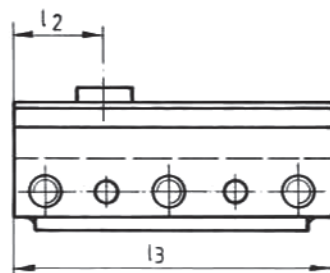

Form B2 Linke Ausführung (wie gezeichnet)
B1 Ausführung rechts (spiegelbildlich)

Form B2 Left side (as drawn)
B1 Right side (mirror image)

Forme B2 Exécution droite dessin ci-dessus
B1 Exécution gauche dessin inverse

Nenngröße h ₁ Size Taille	Nr. Rechts Right Droite	Nr. Links Left Gauche	Maße/Dimensions									
			h ₂	b ₁	b ₂	b ₃ +0,5 0	h ₃	h ₄	h ₅ ± 0,05	h ₆ max.	l ₂	l ₃
16	10.150	10.151	56	39	20	16	26	19	12	22	31	94
20	10.160	10.161	72	47	26	16	34	27	16	29	39	110
25	10.170	10.171	90	49	26	18	42,5	35,5	20	34	39	118
32	10.180	10.181	115	56	33	18	55	40	25,5	41	49	123
40	10.190	10.191	140	67	42	20	67,5	57,5	30	53	59	160

Vierkant-Mehrfachaufnahme

DIN 69881 Teil 4 VDI 3425 Bl. 3
Form C

Multi Purpose Square Toolholder

DIN 69881 Part 4 VDI 3425 Sheet 3
Form C

Radial-Porte outil carré universelle

DIN 69881 Partie 4 VDI 3425 page 3
Forme C

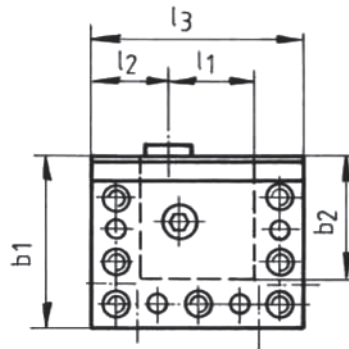
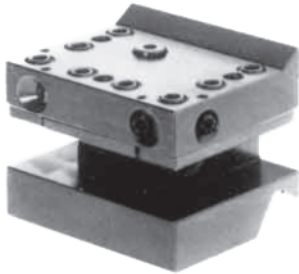

Ausführung A

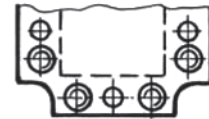
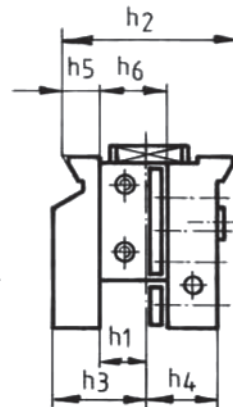

Ausführung B

Form C2 Linke Ausführung (wie gezeichnet)
C1 Ausführung rechts (spiegelbildlich)

Form C2 Left side (as drawn)
C1 Right side (mirror image)

Forme C2 Exécution droite dessin ci-dessus
C1 Exécution gauche dessin inverse

Nenngröße h ₁ Size Taille	Nr. Rechts Right Droite	Nr. Links Left Gauche	Maße/Dimensions									
			h ₂	b ₁	b ₂ +0,5 0	h ₃	h ₄	h ₅ ± 0,05	h ₆ max.	l ₁ +0,5 0	l ₂	l ₃
16	10.200	10.201	56	60	46	40	19	12	22	39	31	84
20	10.210	10.211	72	81	59	43	27	16	29	37	39	98
25	10.220	10.221	90	88	62	50	35,5	20	34	43	39	108
32	10.230	10.231	115	94	68	60	40	25,5	41	43	49	118
40	10.240	10.241	140	115	83	78	57,5	30	53	53	59	144

Vierkant-Mehrfachaufnahme schmal

DIN 69881 Teil 4 VDI 3425 Bl. 3
Form C3

Multi Purpose Square Toolholder narrow

DIN 69881 Part 4 VDI 3425 Sheet 3
Form C3

Radial-Porte outil carré étroit

DIN 69881 Partie 4 VDI 3425 page 3
Forme C3

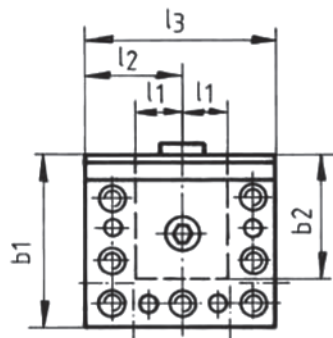
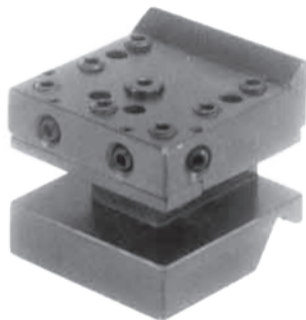

Ausführung A

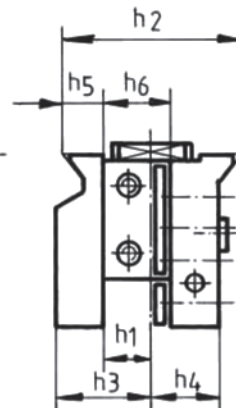

Ausführung B

Nenngröße h ₁ Size Taille	Nr.	Maße/Dimensions									
		h ₂	b ₁	b ₂ +0,5 0	h ₃	h ₄	h ₅ ± 0,05	h ₆ max.	l ₁ +0,5 0	l ₂	l ₃
16	10.250	56	60	46	40	19	12	22	17	31	62
20	10.260	72	81	59	43	27	16	29	17	39	78
25	10.270	90	88	62	50	35,5	20	34	23	49	98
32	10.280	115	94	68	60	40	25,5	41	23	49	98
40	10.290	140	115	83	78	57,5	30	53	27	59	118

**Doppel-Radial-
Werkzeughalter**

Double-Radial-Toolholder

Radial-Porte outil double

DIN 69881 VDI 3425 Bl. 3

DIN 69881 VDI 3425 Sheet 3

DIN 69881 VDI 3425 page 3

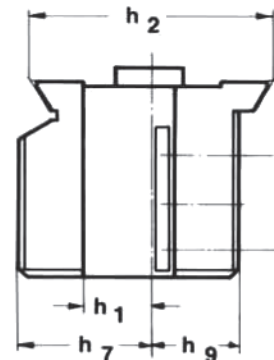
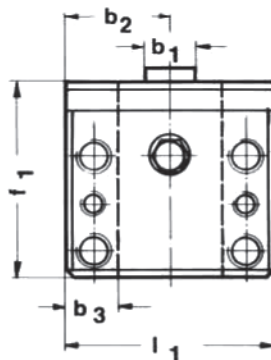
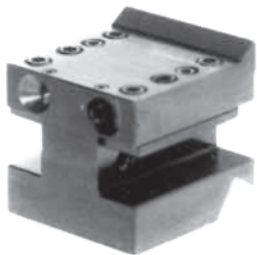

Nenngröße h ₁ Size Taille	Nr.	Maße/Dimensions							
		b ₁	b ₂	b ₃	h ₂	h ₇	h ₉	f ₁	l ₁
16	10.300	16	34	16	56	40	19	60	68
20	10.310	20	39	22	72	43	27	81	78
25	10.320	25	39	25	90	50	35,5	88	78
32	10.330	25	49	26	115	60	40	94	98
40	10.340	25	59	32	140	78	57,5	115	118

2

Zylinderaufnahme

Side Lock Adaptor

Porte outil cylindrique

DIN 69881 Teil 5 VDI 3425 Bl. 3
Form D3

DIN 69881 Part 5 VDI 3425 Sheet 3
Form D3

DIN 69881 Partie 5 VDI 3425 page 3
Forme D3

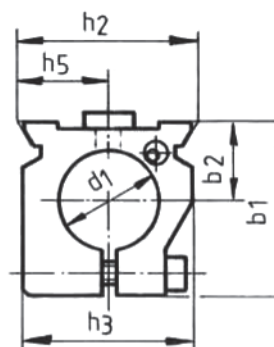
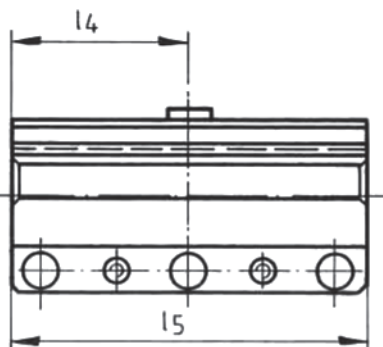
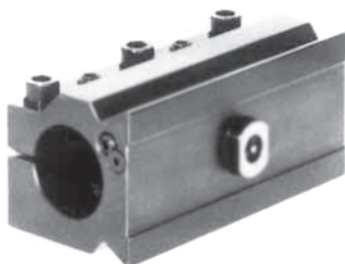

Nenngröße Size Taille	Nr.	Maße/Dimensions							
		h ₂	d ₁ H7	b ₁	b ₂	h ₃	h ₅	l ₄	l ₅
16	10.350	56	32	65	30	52	28	59	118
20	10.360	72	40	76	35	68	36	75	150
25	10.370	90	50	94	45	85	45	99	198
32	10.380	115	60	94	45	93	57,5	99	198
40	10.390	140	80	125	60	115	70	119	238

Nenngröße Size Taille	Nr.	Maße/Dimensions							
		h ₂	d ₁ H7	b ₁	b ₂	h ₃	h ₅	l ₄	l ₅
16	10.355	56	40	65	30	52	28	59	118
20	10.365	72	50	76	35	68	36	75	150
25	10.375	90	60	94	45	85	45	99	198
32	10.385	115	80	115	55	115	57,5	99	198
40	10.395	140	100	145	70	135	70	119	238

Zylinderaufnahme

kurz

DIN 69881 Teil 5 VDI 3425 Bl. 3
Form D

Side Lock Adaptor

short

DIN 69881 Part 5 VDI 3425 Sheet 3
Form D

Porte outil cylindrique

court

DIN 69881 Partie 5 VDI 3425 page 3
Forme D

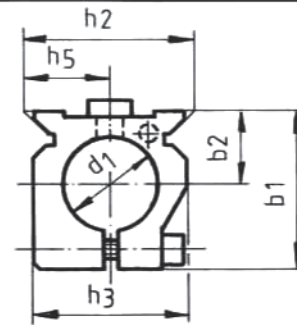
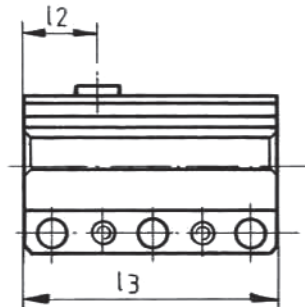

Form

D2 Rechte Ausführung (wie gezeichnet)
D1 Ausführung links (spiegelbildlich)

Form

D2 Right side (as drawn)
D1 Left side (mirror image)

Forme

D2 Exécution droite dessin ci-dessus
D1 Exécution gauche dessin inverse

Nenngröße Size Taille	Nr. Rechts Right Droite	Nr. Links Left Gauche	Maße/Dimensions							
			h_2	d_1 H7	b_1	b_2	h_3	h_5	l_2	l_3
16	10.400	10.401	56	32	65	30	52	28	31	94
20	10.410	10.411	72	40	76	35	68	36	39	110
25	10.420	10.421	90	50	94	45	85	45	39	138
32	10.430	10.431	115	60	94	45	93	57,5	49	148
40	10.440	10.441	140	80	125	60	115	70	59	178

Nenngröße Size Taille	Nr. Rechts Right Droite	Nr. Links Left Gauche	Maße/Dimensions							
			h_2	d_1 H7	b_1	b_2	h_3	h_5	l_2	l_3
16	10.450	10.451	56	40	65	30	52	28	31	94
20	10.460	10.461	72	50	76	35	68	36	39	110
25	10.470	10.471	90	60	94	45	85	45	39	138
32	10.480	10.481	115	80	94	55	115	57,5	49	148
40	10.490	10.491	140	100	125	70	135	70	59	178

Bohrstangenhalter

DIN 69881 VDI 3425 Bl. 3

Boring Bar Holder

DIN 69881 VDI 3425 Sheet 3

Porte barre d'alésage

DIN 69881 VDI 3425 page 3

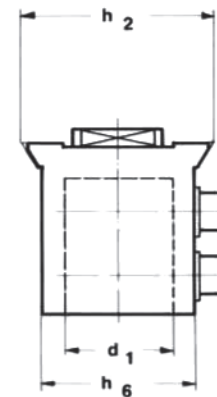
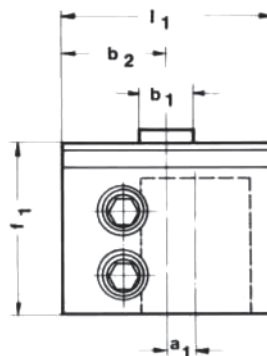
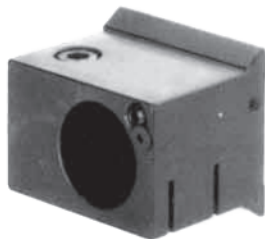

Nenngröße Size Taille	Nr.	Maße/Dimensions							
		d_1	a_1	b_1	b_2	h_2	h_6	f_1	l_1
16	10.500	32	8	16	34	56	39	54	68
20	10.510	40	10	20	39	72	53	65	78
25	10.520	50		25	59	90	71	80	98
32	10.530	60	12,5	25	49	115	95	94	98
40	10.540	80	12,5	25	59	140	115	120	118

Kühlmittelverteiler

Coolant distributor

Bloc d'arrosage

DIN 69881 VDI 3425 Bl. 3

DIN 69881 VDI 3425 Sheet 3

DIN 69881 VDI 3425 page 3

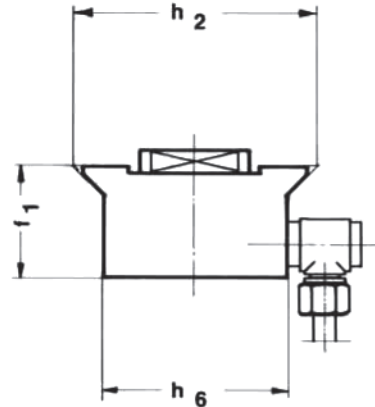
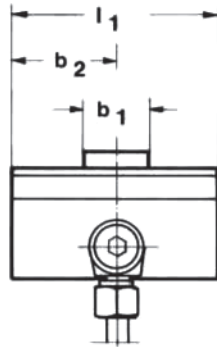

Nenngröße Size Taille	Nr.	Maße/Dimensions		h ₂	h ₆	f ₁	l ₁
		b ₁	b ₂				
16	10.550	16	34	56	39	28	68
20	10.560	20	39	72	53	34	78
25	10.570	25	39	90	71	42	78
32	10.580	25	49	115	95	54	98
40	10.590	25	59	140	115	60	118

2

Stellhülseaufnahme

Automotive Sleeves

Porte outil pour embout de réglage

DIN 69881 VDI 3425 Bl. 3

DIN 69881 VDI 3425 Sheet 3

DIN 69881 VDI 3425 page 3

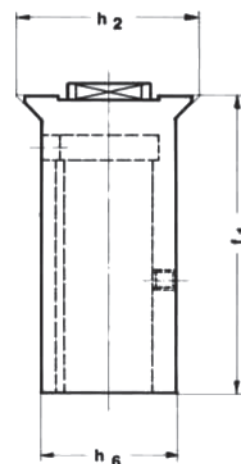
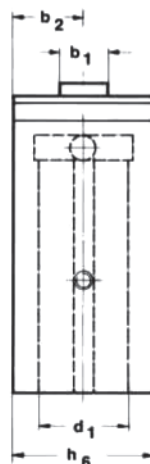
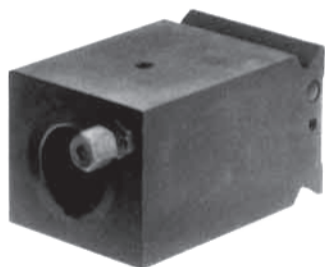

Nenngröße Size Taille	Nr.	Maße/Dimensions		b ₂	h ₂	h ₆	f ₁
		d ₁	b ₁				
16	10.600	36	16	26	56	52	120
20	10.610	36	20	26	72	52	120
25	10.620	48	25	35,5	90	71	140
32	10.630	48	25	47,5	115	95	140
40	10.640	48	25	57,5	140	115	140

Stellhülseaufnahme

Automotive Sleeves

Porte outil pour embout de réglage

DIN 69881 VDI 3425 Bl. 3

DIN 69881 VDI 3425 Sheet 3

DIN 69881 VDI 3425 page 3

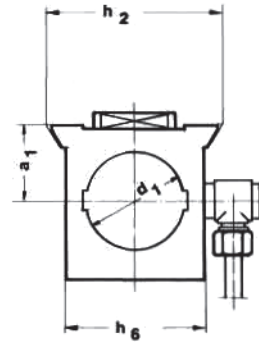
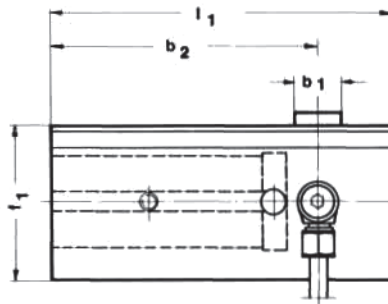
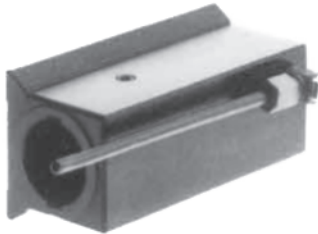

Nenngröße Size Taille	Nr.	Maße/Dimensions							
		d ₁	b ₁	b ₂	h ₂	h ₆	f ₁	l ₁	a ₁
16	10.650	36	16	90	56	52	58	119	30
20	10.660	36	20	100	72	52	58	139	30
25	10.670	48	25	135	90	71	80	174	40
32	10.680	48	25	175	115	95	80	224	40
40	10.690	48	25	175	140	115	80	224	40

Mehrfach-Werkzeughalter

Multi-Toolholder

Porte outil multiple

schmal, lange Ausführung

narrow, long

étroit, Execution longue

DIN 69881 VDI 3425 Bl. 3

DIN 69881 VDI 3425 Sheet 3

DIN 69881 VDI 3425 page 3

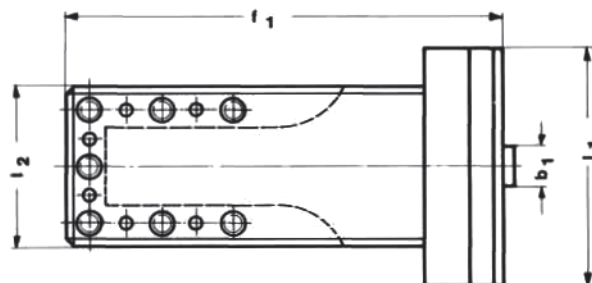
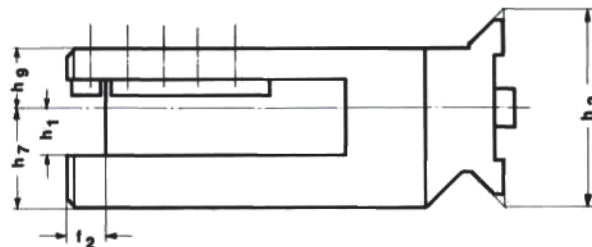
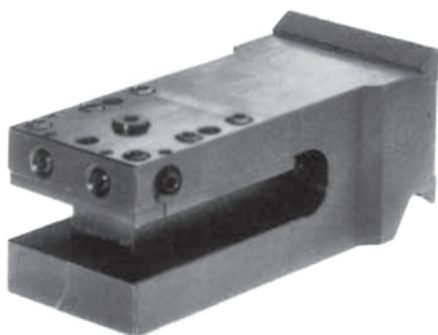

Nenngröße h ₁ Size Taille	Nr.	Maße/Dimensions							
		h ₂	h ₇	h ₉	b ₁	f ₁	f ₂	l ₁	l ₂
16	10.700	56	40	19	16	160	15	62	55
20	10.710	72	42,5	26	20	180	18	82	70
25	10.720	90	50	30	25	200	22	78	78
32	10.730	115	60	40	25	220	28	118	98
40	10.740	140	80	57	25	240	32	155	118

Doppel-Bohrstangenhalter Double-Boring Bar Holder Porte barre double

DIN 69881 VDI 3425 Bl. 3 DIN 69881 VDI 3425 Sheet 3 DIN 69881 VDI 3425 page 3

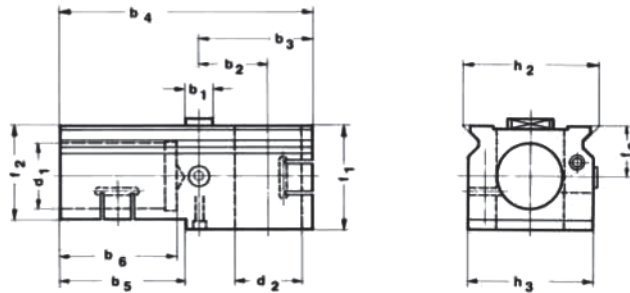
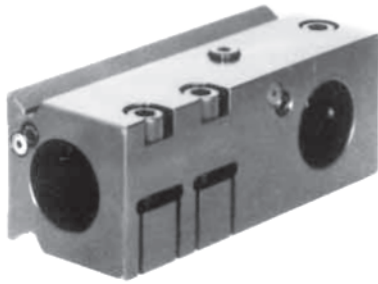

Nenngröße Size Taille	Nr.	Maße/Dimensions			h ₃	b ₁	b ₂	b ₃	b ₄	b ₅	b ₆	f ₁	f ₂	f ₃
		h ₂	d ₁	d ₂										
20	10.760	72	40	40	68	20	40	75	175		80	70	70	35
25	10.770	90	50	50	85	25	45	80	210	120	110	85	75	40
32	10.780	115	60	60	110	25	62,5	102	227	150	125	94	85	45
40	10.790	140	80	80	135	25	65	120	300	170	150	125	115	60

2

Werkzeughalterplatte Toolholder Plate Flasque porte outil

DIN 69881 VDI 3425 Bl. 3 DIN 69881 VDI 3425 Sheet 3 DIN 69881 VDI 3425 page 3



Lange Ausführung
Long execution
Exécution longue

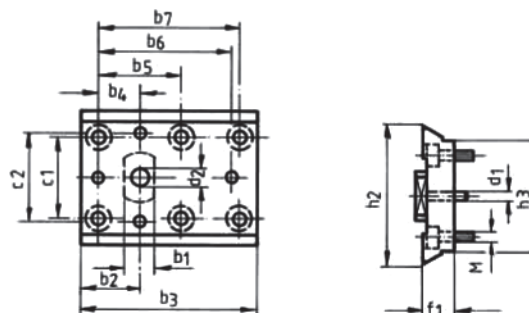

Nenngröße Size Taille	Nr.	Maße/Dimensions				b ₃	b ₄	b ₅	b ₆	b ₇	c ₁	c ₂	f ₁	M	d ₁	d ₂
		h ₂	h ₃	b ₁	b ₂											
20	10.810	72	53	20	39	98	25		70	30	40	20	M8	6	13	
25	10.820	90	71	25	39	115	25	50	87	87	55	55	M10	8	15	
32	10.830	115	95	25	49	148	35	70	115	120	70	70	M10	8	15	
40	10.840	140	115	25	59	200	45	90	172	172	90	90	M12	10	15	

Kurze Ausführung
Short execution
Exécution court

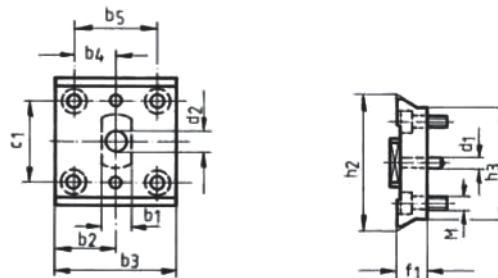

Nenngröße Size Taille	Nr.	Maße/Dimensions				b ₃	b ₄	b ₅	c ₁	f ₁	M	d ₁	d ₂
		h ₂	h ₃	b ₁	b ₂								
20	10.815	72	53	20	39	78	25	50	30	20	M8	6	13
25	10.825	90	71	25	39	78	25	50	55	25	M10	8	15
32	10.835	115	95	25	49	98	35	70	70	25	M10	8	15
40	10.845	140	115	25	59	160	45	132	90	35	M12	10	15

Bohrhalter für Wendeplattenbohrer

DIN 69881 VDI 3425 Bl. 3

Boring Holder for Carbide Tip Boring

DIN 69881 VDI 3425 Sheet 3

Porte outil pour forst à plaquette carbure

DIN 69881 VDI 3425 page 3

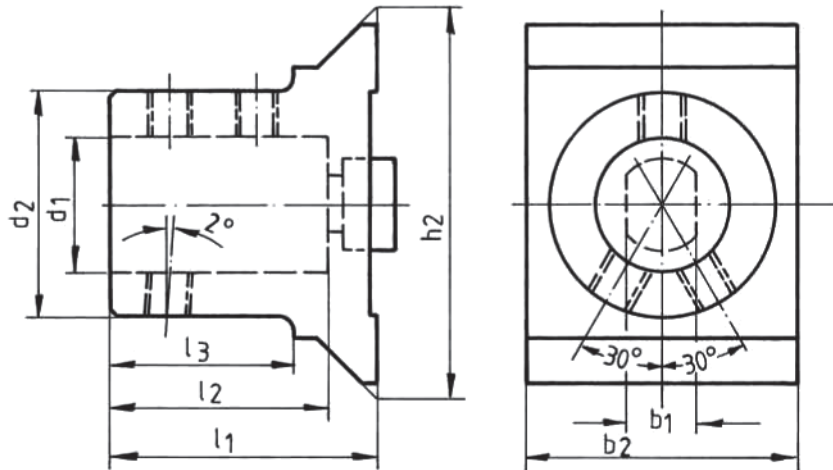

Nenngröße Size Taille	Nr.	Maße/Dimensions							
		h_2	b_1	b_2	d_1	d_2	l_1	l_2	l_3
16	10.900/20	56	16	68	20	44	66	54	44
16	10.900/25	56	16	68	25	49	71	59	49
16	10.900/32	56	16	68	32	56	75	63	54
16	10.900/40	56	16	68	40	64	85	73	60
20	10.910/20	72	20	78	20	44	66	54	44
20	10.910/25	72	20	78	25	49	71	59	49
20	10.910/32	72	20	78	32	56	75	63	54
20	10.910/40	72	20	78	40	64	85	73	60
20	10.910/50	72	20	78	50	74	95	83	70
25	10.920/20	90	25	98	20	44	66	54	44
25	10.920/25	90	25	98	25	49	71	59	49
25	10.920/32	90	25	98	32	56	75	63	54
25	10.920/40	90	25	98	40	64	85	73	60
25	10.920/50	90	25	98	50	74	95	83	70
32	10.930/20	115	25	98	20	44	66	54	44
32	10.930/25	115	25	98	25	49	71	59	49
32	10.930/32	115	25	98	32	56	75	63	54
32	10.930/40	115	25	98	40	64	85	73	60
32	10.930/50	115	25	98	50	74	95	83	70
40	10.940/20	140	25	118	20	44	66	54	44
40	10.940/25	140	25	118	25	49	71	59	49
40	10.940/32	140	25	118	32	56	75	63	54
40	10.940/40	140	25	118	40	64	85	73	60
40	10.940/50	140	25	118	50	74	95	83	70

Bohrhalter für Wendeplattenbohrer

DIN 69881 VDI 3425 Bl. 3

Boring Holder for Carbide Tip Boring

DIN 69881 VDI 3425 Sheet 3

Porte outil pour forst à plaquette carbure

DIN 69881 VDI 3425 page 3

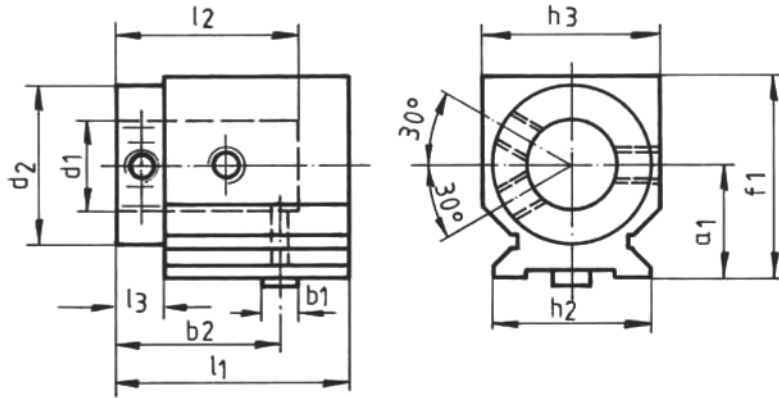
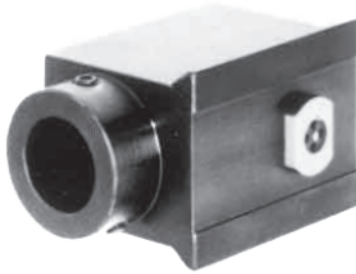

2

Nenngröße Size Taille	Nr.	Maße/Dimensions										
		a ₁	b ₁	b ₂	d ₁	d ₂	f ₁	h ₂	h ₃	l ₁	l ₂	l ₃
16	10.950/20	40	16	75	20	44	76	56	66	109	54	28
16	10.950/25	40	16	75	25	49	76	56	66	109	59	28
16	10.950/32	40	16	75	32	56	76	56	66	109	63	28
16	10.950/40	40	16	75	40	64	76	56	66	109	73	32
20	10.960/20	45	20	80	20	44	78	72	68	119	54	28
20	10.960/25	45	20	80	25	49	78	72	68	119	59	28
20	10.960/32	45	20	80	32	56	78	72	68	119	63	28
20	10.960/40	45	20	80	40	64	78	72	68	119	73	32
20	10.960/50	45	20	80	50	74	78	72	68	119	83	34
25	10.970/20	50	25	100	20	44	86	90	80	139	54	28
25	10.970/25	50	25	100	25	49	86	90	80	139	59	28
25	10.970/32	50	25	100	32	56	86	90	80	139	63	28
25	10.970/40	50	25	100	40	64	86	90	80	139	73	32
25	10.970/50	50	25	100	50	74	86	90	80	139	83	34
32	10.980/20	55	25	100	20	44	95	115	94	149	54	28
32	10.980/25	55	25	100	25	49	95	115	94	149	59	28
32	10.980/32	55	25	100	32	56	95	115	94	149	63	28
32	10.980/40	55	25	100	40	64	95	115	94	149	73	32
32	10.980/50	55	25	100	50	74	95	115	94	149	83	34
40	10.990/20	60	25	120	20	44	100	140	114	189	54	28
40	10.990/25	60	25	120	25	49	100	140	114	189	59	28
40	10.990/32	60	25	120	32	56	100	140	114	189	63	28
40	10.990/40	60	25	120	40	64	100	140	114	189	73	32
40	10.990/50	60	25	120	50	74	100	140	114	189	83	34

WH-Werkzeughalter für Bohrstangen

DIN 69881 VDI 3425 Bl. 3
Durchmesser und Drehmitte einstellbar

WH-Toolholder for Boring Bars

DIN 69881 VDI 3425 Sheet 3
Diameter and Centre turning point adjustable

Porte outil WH pour alésage

DIN 69881 VDI 3425 page 3
Diamètre et centrage réglables

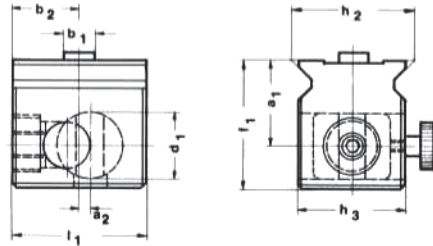

Nenngröße Size Taille	Nr.	Maße/Dimensions								
		d ₁	a ₁	a ₂	b ₁	b ₂	f ₁	h ₂	h ₃	l ₁
16	30.100	36	41	4	16	34	64	56	52	68
20	30.110	46	48	6	20	38	76	72	66	78
25	30.120	46	50	6	25	38	78	90	66	78
32	30.130	46	52	6	25	38	80	115	66	78
40	30.140	46	56	6	25	38	84	140	66	78

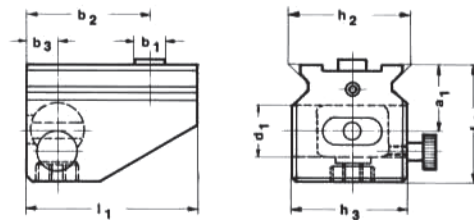

Nenngröße Size Taille	Nr.	Maße/Dimensions								
		d ₁	a ₁	b ₁	b ₂	b ₃	f ₁	h ₂	h ₃	l ₁
16	30.150	36	39	16	59	23	77	56	52	93
20	30.160	46	48	20	75	28	93	72	66	114
25	30.170	46	50	25	89	28	95	90	66	138
32	30.180	46	52	25	99	28	97	115	66	148
40	30.190	46	55	25	119	28	100	140	66	188

WH-Wechselhalter

WH-Infeed Toolholders

WH-Supports interchangeable

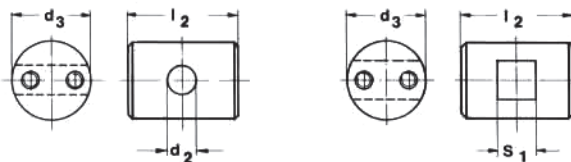

Nr.	Maße/Dimensions			Nr.	Maße/Dimensions			Nr.	Maße/Dimensions		
	d ₁	d ₂	l ₂		d ₁	d ₂	l ₂		d ₁	s ₁	l ₂
200.208	36	8	38	200.312	46	12	52	210.210	36	10	38
200.210	36	10	38	200.313	46	13	52	210.212	36	12	38
200.212	36	12	38	200.314	46	14	52	210.216	36	16	38
200.213	36	13	38	200.315	46	15	52	210.312	46	12	52
200.214	36	14	38	200.316	46	16	52	210.316	46	16	52
200.215	36	15	38	200.320	46	20	52	210.320	46	20	52
200.216	36	16	38	200.325	46	25	52				

Wechselhalter mit weiteren d₂ und s₁ Maßen auf Anfrage

Infeed Toolholders with further d₂ and s₁ measurements on request

Support interchangeable avec autre dimension pour d₂ ou s₁ sur demande

Aufnahmehülsen

Adaptor Sleeve

Douille de réduction



Nr.	Maße/Dimensions			Nr.	Maße/Dimensions		
	d ₃	d ₂	l ₁		d ₃	d ₂	l ₁
100.110.32.060.	32	10	60	100.125.50.100	50	25	100
100.112.32.060	32	12	60	100.132.50.100	50	32	100
100.115.32.060	32	15	60	100.115.60.115	60	15	115
100.116.32.060	32	16	60	100.116.60.115	60	16	115
100.120.32.060	32	20	60	100.120.60.115	60	20	115
100.110.40.080	40	10	80	100.125.60.115	60	25	115
100.112.40.080	40	12	80	100.132.60.115	60	32	115
100.115.40.080	40	15	80	100.140.60.115	60	40	115
100.116.40.080	40	16	80	100.132.80.130	80	32	130
100.120.40.080	40	20	80	100.140.80.130	80	40	130
100.125.40.080	40	25	80	100.150.80.130	80	50	130
100.110.50.100	50	10	100	100.160.80.130	80	60	130
100.112.50.100	50	12	100	100.140.100.170	100	40	170
100.115.50.100	50	15	100	100.150.100.170	100	50	170
100.116.50.100	50	16	100	100.160.100.170	100	60	170
100.120.50.100	50	20	100	100.180.100.170	100	80	170

Aufnahmehülsen mit weiteren Maßen auf Anfrage

Adaptorsleeve with further measurements on request

Douille de réduction avec autres dimensions sur demande

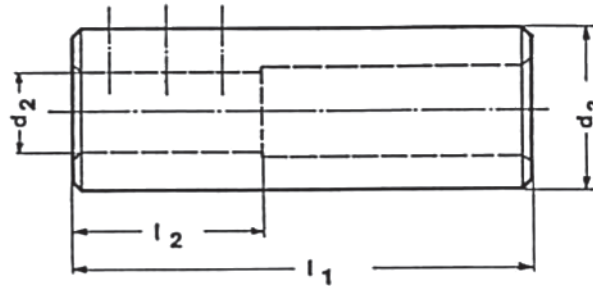

Nr.	Maße/Dimensions				Nr.	Maße/Dimensions			
	d ₃	d ₂	l ₁	l ₂		d ₃	d ₂	l ₁	l ₂
150.110.32.110	32	10	110	40	150.116.50.140	50	16	140	50
150.112.32.110	32	12	110	40	150.120.50.140	50	20	140	60
150.115.32.110	32	15	110	50	150.125.50.140	50	25	140	70
150.116.32.110	32	16	110	50	150.132.50.140	50	32	140	80
150.120.32.110	32	20	110	60	150.115.60.150	60	15	150	50
150.110.40.130	40	10	130	40	150.116.60.150	60	16	150	50
150.112.40.130	40	12	130	40	150.120.60.150	60	20	150	60
150.115.40.130	40	15	130	50	150.125.60.150	60	25	150	70
150.116.40.130	40	16	130	50	150.132.60.150	60	32	150	80
150.120.40.130	40	20	130	60	150.140.60.150	60	40	150	100
150.125.40.130	40	25	130	70	150.132.80.180	80	32	180	80
150.110.50.140	50	10	140	40	150.140.80.180	80	40	180	100
150.112.50.140	50	12	140	40	150.150.80.180	80	50	180	120
150.115.50.140	50	15	140	50	150.160.80.180	80	60	180	140

Aufnahmehülsen mit weiteren Maßen auf Anfrage

Adaptorsleeve with further measurements on request

Douille de réduction avec autres dimensions sur demande

Aufnahmehülsen geschlitzt

Adaptor Sleeve split

Douille de réduction fendue

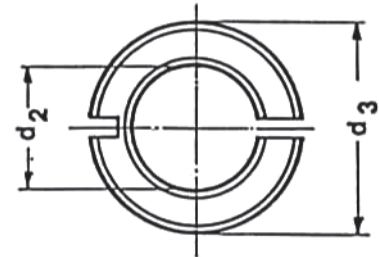
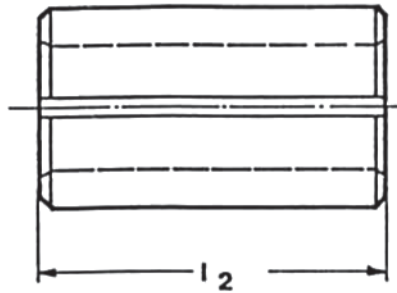

Nr.	Maße/Dimensions			Nr.	Maße/Dimensions		
	d ₃	d ₂	l ₂		d ₃	d ₂	l ₂
400.108.32.65	32	8	65	400.120.40.75	40	20	75
400.110.32.65	32	10	65	400.125.40.75	40	25	75
400.112.32.65	32	12	65	400.125,4.40.75	40	25,4	75
400.112,7.32.65	32	12,7	65	400.130.40.75	40	30	75
400.114.32.65	32	14	65	400.132.40.75	40	32	75
400.115.32.65	32	15	65	400.110.50.85	50	10	85
400.116.32.65	32	16	65	400.112.50.85	50	12	85
400.118.32.65	32	18	65	400.116.50.85	50	16	85
400.119,05.32.65	32	19,05	65	400.120.50.85	50	20	85
400.120.32.65	32	20	65	400.125.50.85	50	25	85
400.125.32.65	32	25	65	400.130.50.85	50	30	85
400.125,4.32.65	32	25,4	65	400.132.50.85	50	32	85
400.108.40.75	40	8	75	400.140.50.85	50	40	85
400.110.40.75	40	10	75	400.112.60.95	60	12	95
400.112.40.75	40	12	75	400.116.60.95	60	16	95
400.112,7.40.75	40	12,7	75	400.120.60.95	60	20	95
400.114.40.75	40	14	75	400.125.60.95	60	25	95
400.115.40.75	40	15	75	400.130.60.95	60	30	95
400.116.40.75	40	16	75	400.132.60.95	60	32	95
400.118.40.75	40	18	75	400.140.60.95	60	40	95
400.119,05.40.75	40	19,05	75	400.150.60.95	60	50	95

Aufnahmehülsen mit weiteren Maßen auf Anfrage

Adaptorsleeve with further measurements on request

Douille de réduction avec autres dimensions sur demande

Bohrerhalter

Morsetaper Sleeve

Douille porte forêt

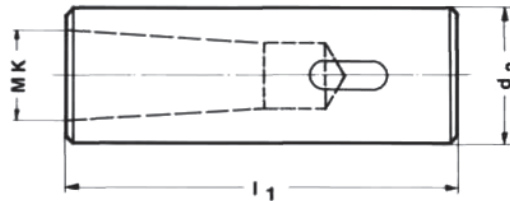

Nr.	Maße/Dimensions			Nr.	Maße/Dimensions		
	d ₃	MK	l ₁		d ₃	MK	l ₁
500.101.32.092	32	1	92	500.103.60.148	60	3	148
500.102.32.092	32	2	92	500.104.60.148	60	4	148
500.103.32.092	32	3	92	500.105.60.148	60	5	148
500.101.40.092	40	1	92	500.103.60.180	60	3	180
500.102.40.092	40	2	92	500.104.60.180	60	4	180
500.103.40.092	40	3	92	500.105.60.180	60	5	180
500.104.40.115	40	4	115	500.104.80.180	80	4	180
500.102.50.115	50	2	115	500.105.80.180	80	5	180
500.103.50.115	50	3	115	500.104.100.180	100	4	180
500.104.50.115	50	4	115	500.105.100.180	100	5	180

Bohrerhalter mit weiteren Maßen auf Anfrage

Morsetaper with further measurements on request

Douille porte foret avec autres dimensions sur demande

Spannzangenfutter

mit Zylinderschaft

Collet Chuck

with cylindrical shaft

Mandrin à pince

à queue cylindrique

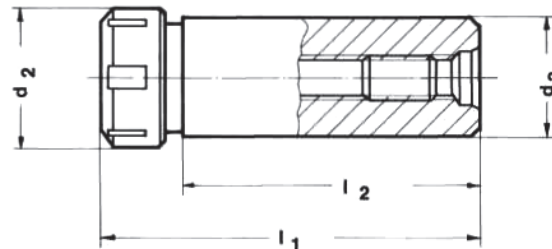

Nr.	Spannbereich		Maße/Dimensions		l ₁	l ₂	Spannzangen	Spannschlüssel
	Satz	Zange	d ₂	d ₃				
700.116/32	1-16	1	42	32	120	80	250 430 E	225
700.116/40	1-16	1	42	40	120	88	250 430 E	225
700.120/32	2-20	1	50	32	142	90	320 470 E	232
700.120/40	2-20	1	50	40	142	90	320 470 E	232
700.126/40	3-26	1	63	40	160	100	400 472 E	240
700.126/50	3-26	1	63	50	160	100	400 472 E	240

Stellhülsen

kurze Bauart

DIN 6327

Automotive to Morsetaper

Short

DIN 6327

Embout de réglage

Court

DIN 6327

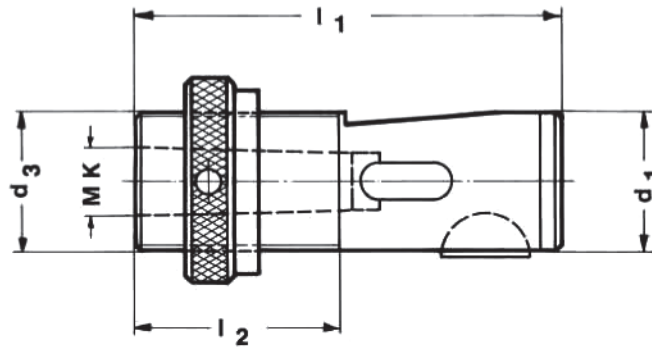

Nr.	Maße/Dimensions				
	MK	d ₁	d ₃	l ₁	l ₂
0120	1	28	Tr 28x2	95	42
0121	2	28	Tr 28x2	95	42
0126	2	36	Tr 36x2	118	50
0127	3	36	Tr 36x2	118	50
0134	3	48	Tr 48x2	144	65
0135	4	48	Tr 48x2	144	65

Reduzierhülsen

DIN 2185

Reducer Sleeve

DIN 2185

Douille de réduction

DIN 2185

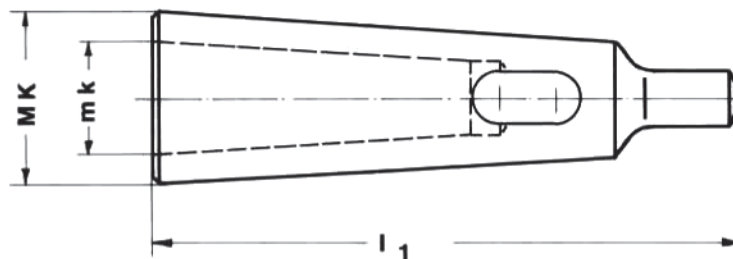

Nr.	Maße/Dimensions			Nr.	Maße		
	MK	mk	l ₁		MK	mk	l ₁
3002	2	1	92	3005	4	1	124
3003	3	1	99	3006	4	2	124
3004	3	2	112	3007	4	3	140

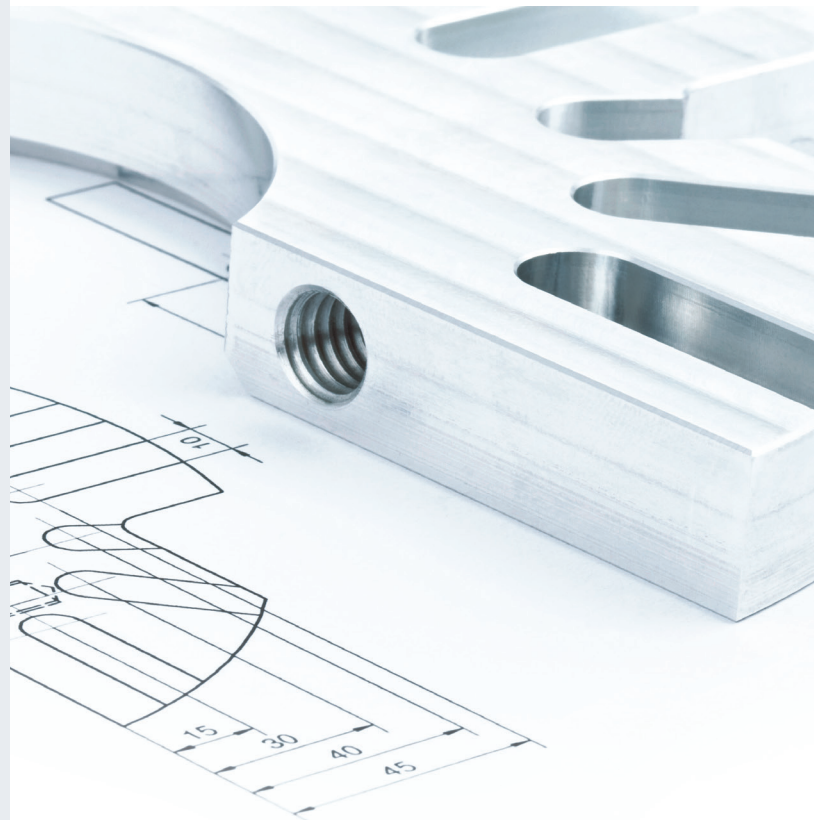

EWS Weigele GmbH & Co. KG

Maybachstraße 1 · D-73066 Uhingen
Telefon +49(0)7161-93040-100
Telefax +49(0)7161-93040-30
E-Mail: info@ews-tools.de
www.ews-tools.de

WSW Spannwerkzeuge-Vertriebs GmbH

Maybachstr. 1 · D-73066 Uhingen
Telefon +49(0)7161-93040-100
Telefax +49(0)7161-93040-30
E-Mail: info@wsw-collets.de
www.wsw-collets.de

Command Tooling Systems

13931 Sunfish Lake Blvd NW
Ramsey · MN 55303 USA
Telefon +1-763-576-6910
Telefax +1-763-576-6911
support@commandtool.com
www.commandtool.com

EWS Korea Co. Ltd.

60-11 · Woongnam-Dong
Changwon
Kyoung-Nam Korea
Telefon +82 55-267-8085
Telefax +82 55-262-3118
E-Mail: info@ewskorea.co.kr
www.ewskorea.co.kr

EWS Ltd.

B. Nizhegorodskaya str., 81
office 806
600000 Vladimir Russland
Telefon: +7-4922-490420
Fax: +7-4922-451828
info@ews-russland.ru
www.ews-russland.ru

